



Space Mission Concepts To Image Earth-Like Planets In Habitable Zones

Robert J. Vanderbei

2010 December 6

American Museum of Natural History
New York, NY

<http://www.princeton.edu/~rvdb>

Jan 1, 2000

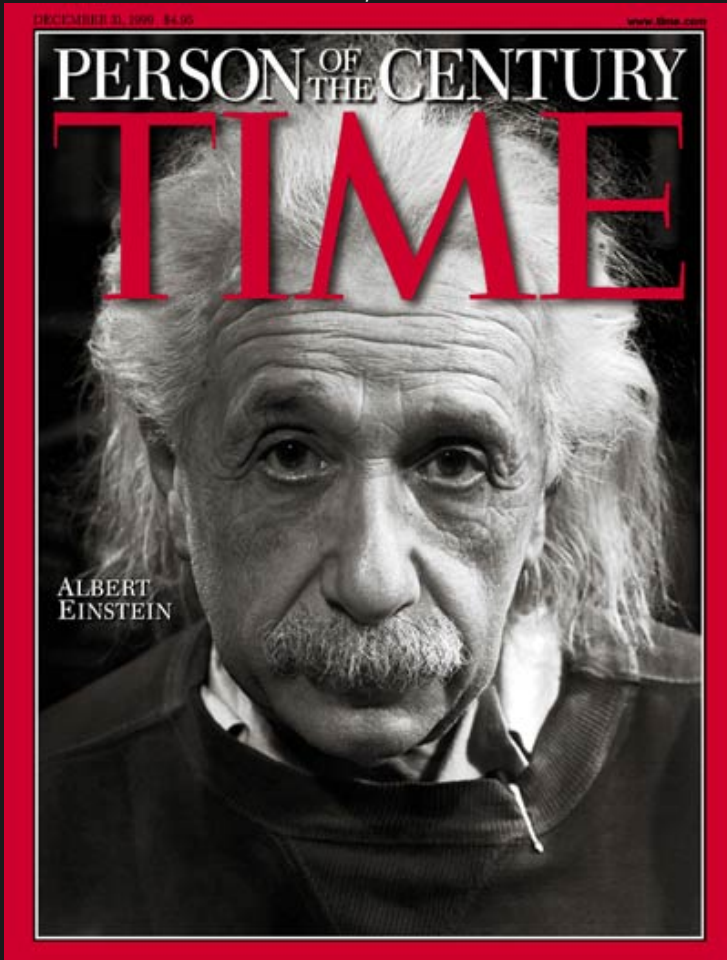

Jan 1, 2100?

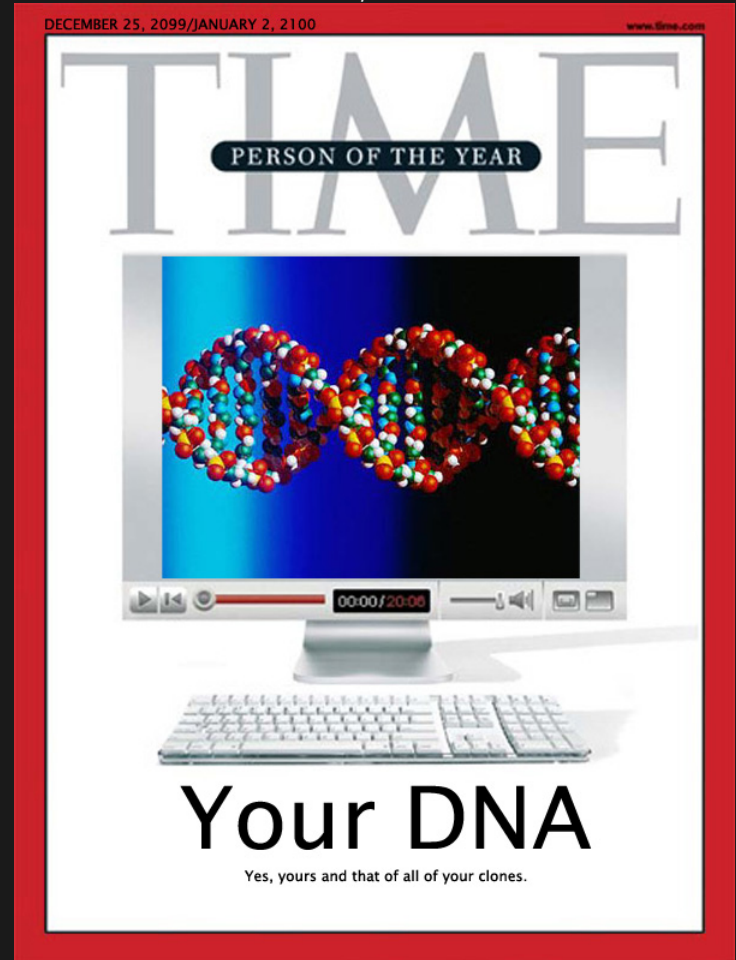

Are We Alone?

What Are The Odds?



Are We Alone?

What Are The Odds?

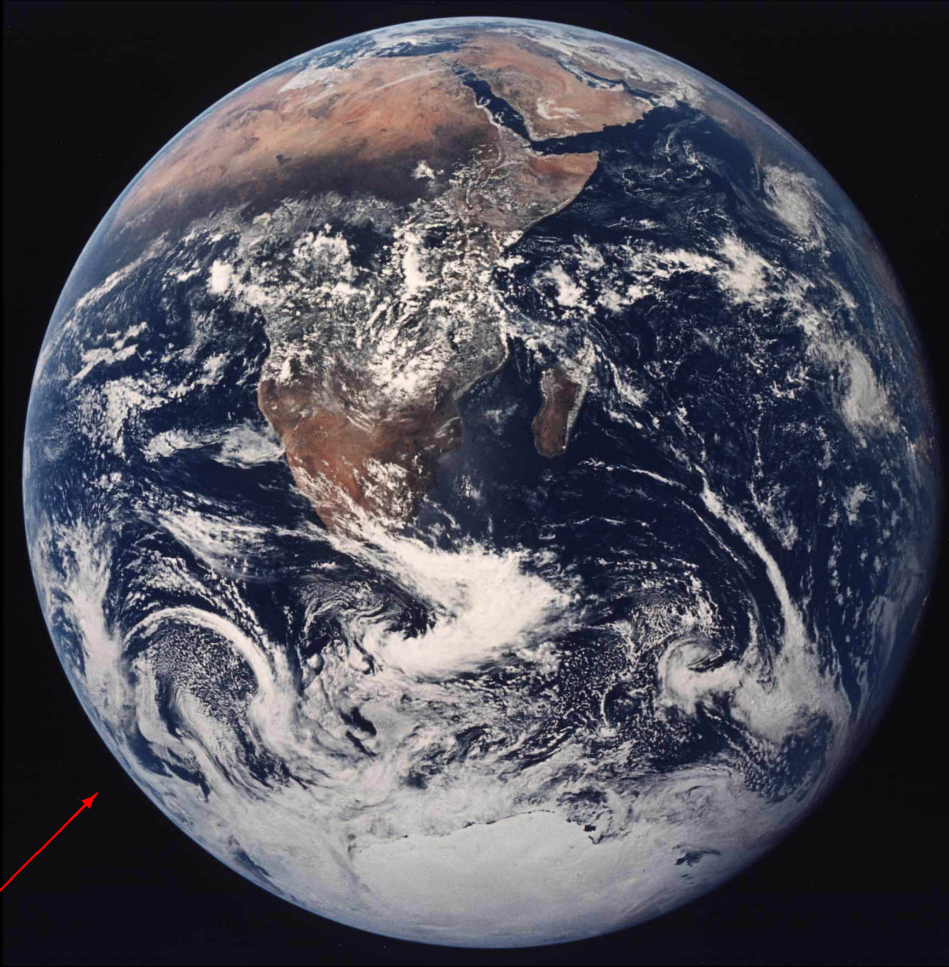

This is Earth

Indirect Detection Methods

About 400 planets found so far

Wobble Methods

Radial Velocity.

For edge-on systems.

Measure periodic doppler shift.

Astrometry.

Best for face-on systems.

Measure circular wobble against background stars.

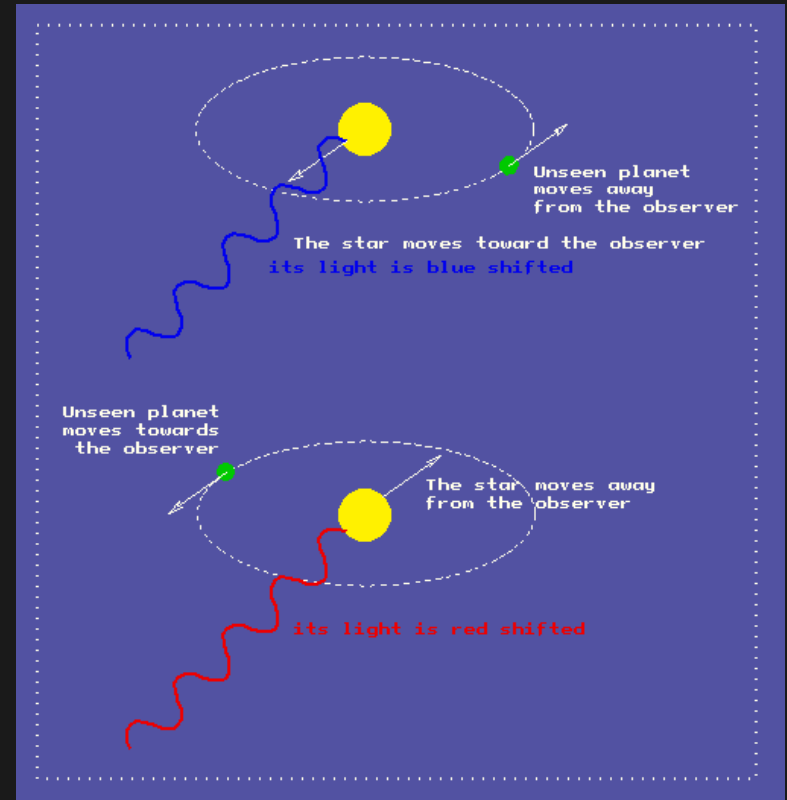

First Discovery: 51 Pegasi b

- Mayor and Queloz (1995)
- Mag. 5.5
main sequence star
- Detected by *radial velocity* method
- Velocity difference:
70 m/s = 160 mph
- Period: 4.2 days
- Separation: 0.05 AU
- Angular separation:
0.0035 arcseconds
- Mass: $> 0.47M_J$
- Hot Jupiter

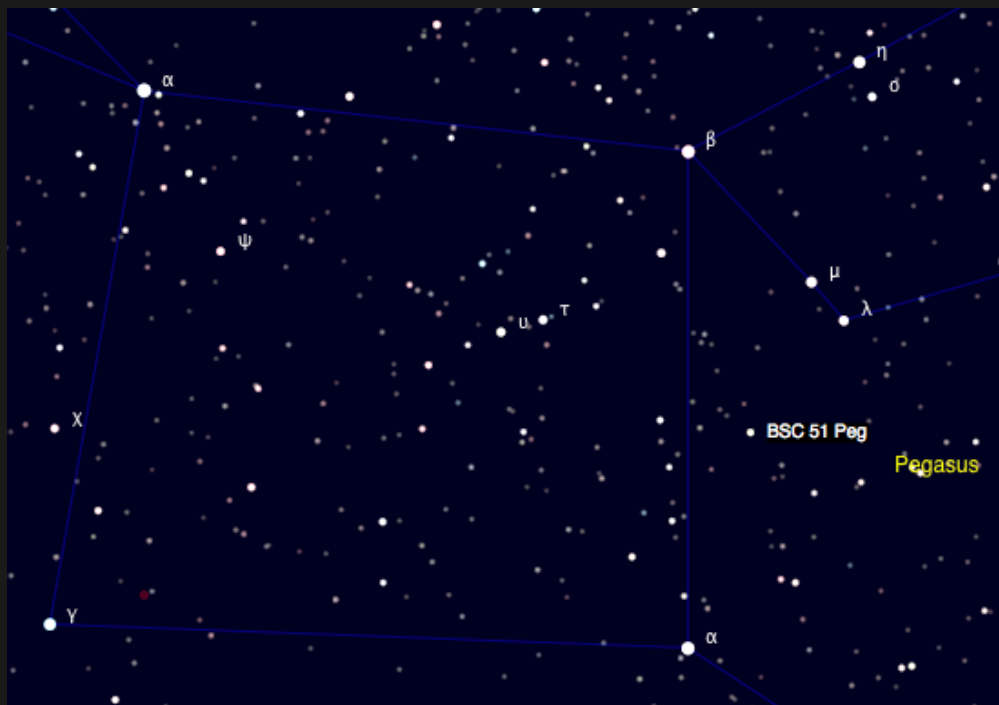

Notable Recent Discoveries

Gliese 581c (Possibly Terrestrial)

- Mag. 10.5 red dwarf
- Detected by *radial velocity* method
- Period: 13 days
- Separation: 0.07 AU
- Angular Separation: 0.012 arcseconds
- Mass: $> 5M_E$



Transit Method

- HD209458b confirmed both via RV and transit.
- Period: 3.5 days
- Separation: 0.045 AU (0.001 arcsecs)
- Radius: $1.3R_J$
- Intensity Dip: $\sim 1.7\%$
- Venus Dip = 0.01%, Jupiter Dip: 1%
- Kepler and Corot



Venus Transit (R.J. Vanderbei)



HD209458

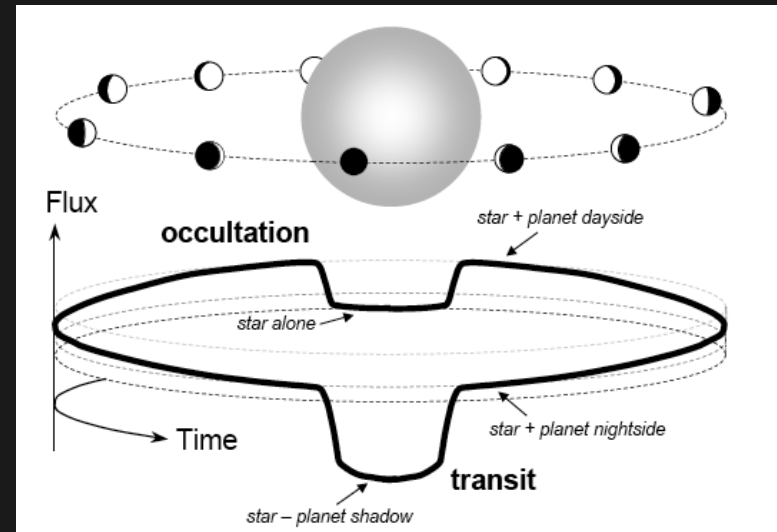

■ EXOPLANETS COMPARED

PLANETS ARE SHOWN to scale in silhouette against their stars as if seen in transit. The sun and its planets, Pluto, and some moons are shown for comparison. We can discover the sizes of extrasolar planets by noting the fraction of their star's light they block if they transit in front of it. Most planets discovered to date are very close to their stars and hence too hot to allow liquid water on their surface. Planet HD 209458b is a hot gas-giant planet like Jupiter. Planet GJ 436b is a hot Neptune-like planet. It's hot because it is so close to its star, even though that star is a cool M-dwarf. CoRoT-7b is the smallest transiting planet discovered so far—its diameter is only 1.7 times greater than Earth's diameter. It is a rocky planet with a temperature of more than 1300K.

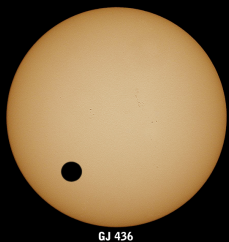

GJ 436



CoRoT-7

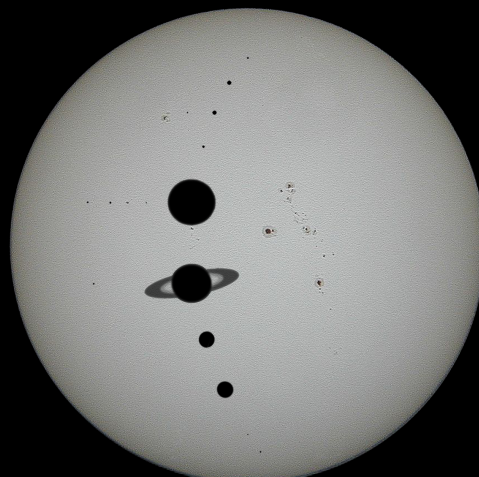

Sun (for comparison)



HD 209458



Gravitational Lensing (OGLE)

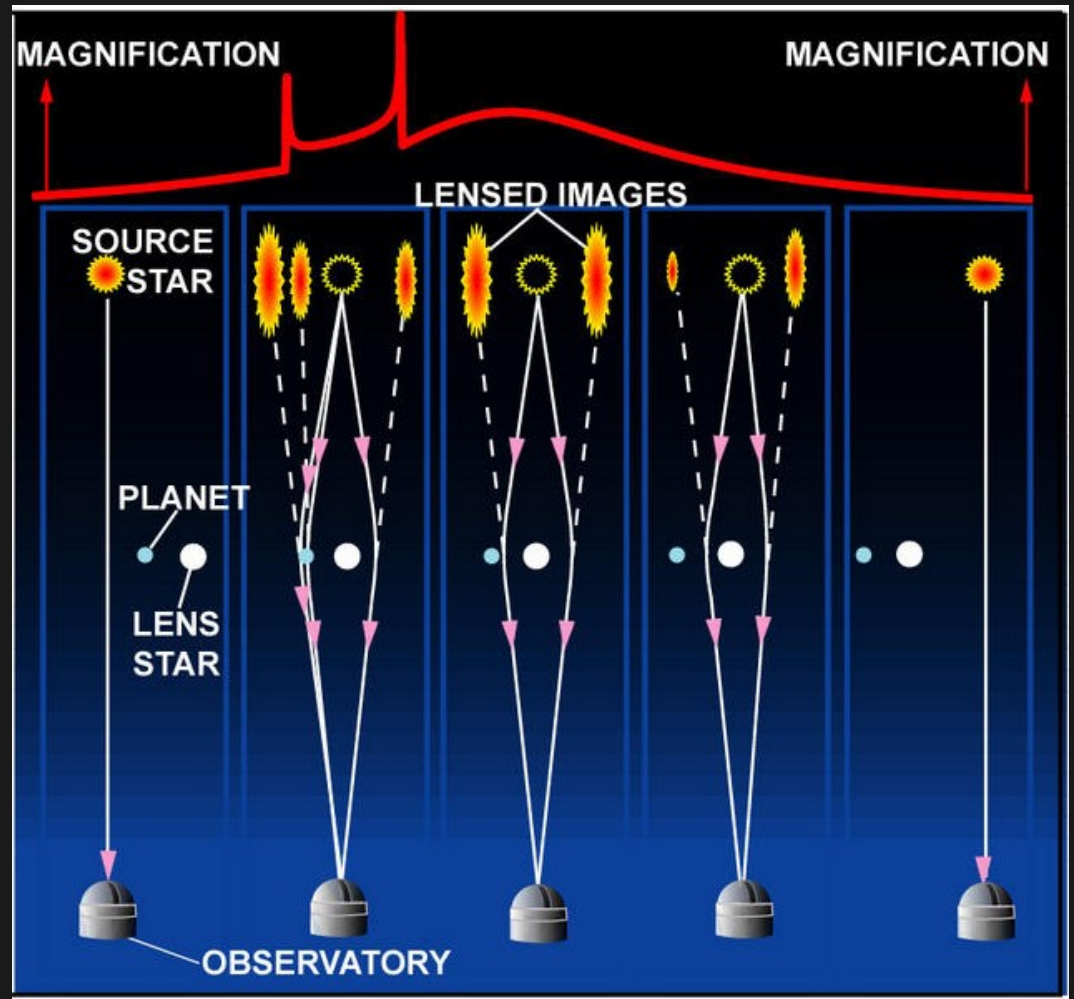

Handful of discoveries.

Astrometry

- *Space Interferometry Mission (SIM)*
- Wobbles as small as 0.000001 arcsecs (the thickness of a nickel viewed from the distance of the moon).
- Mission Cancelled
- Mission Reborn?

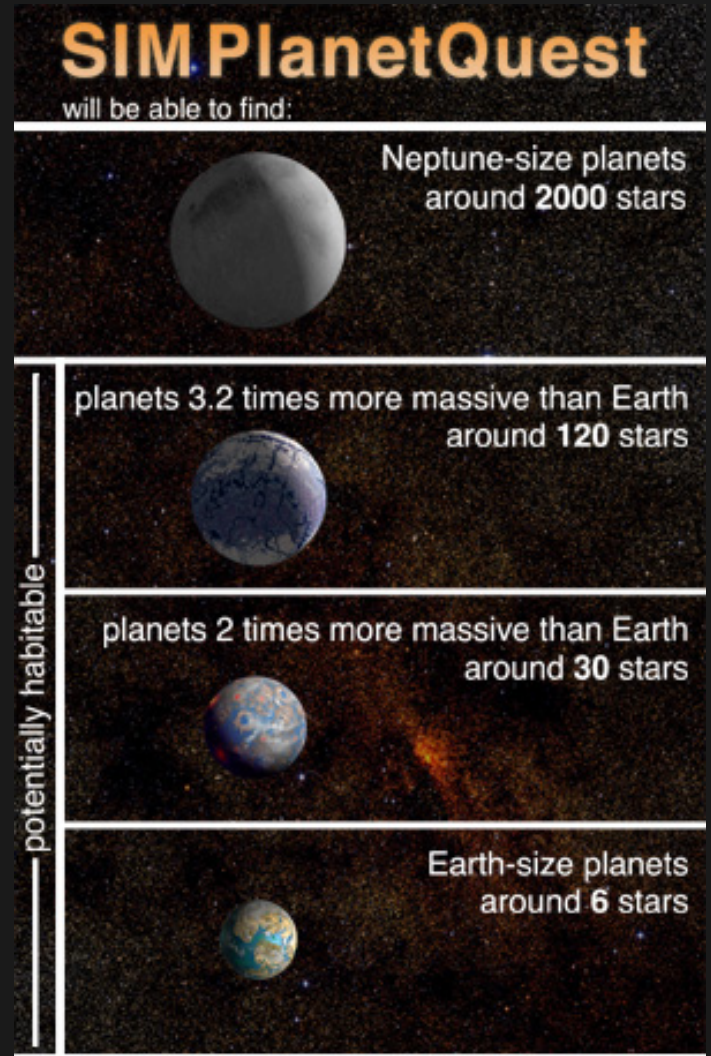

Direct Detection

Fomalhaut (First Detection via Direct Imaging)

Mag. 1.2,

Distance 25 ly,

Imaged by HST,

Period: 872 years,

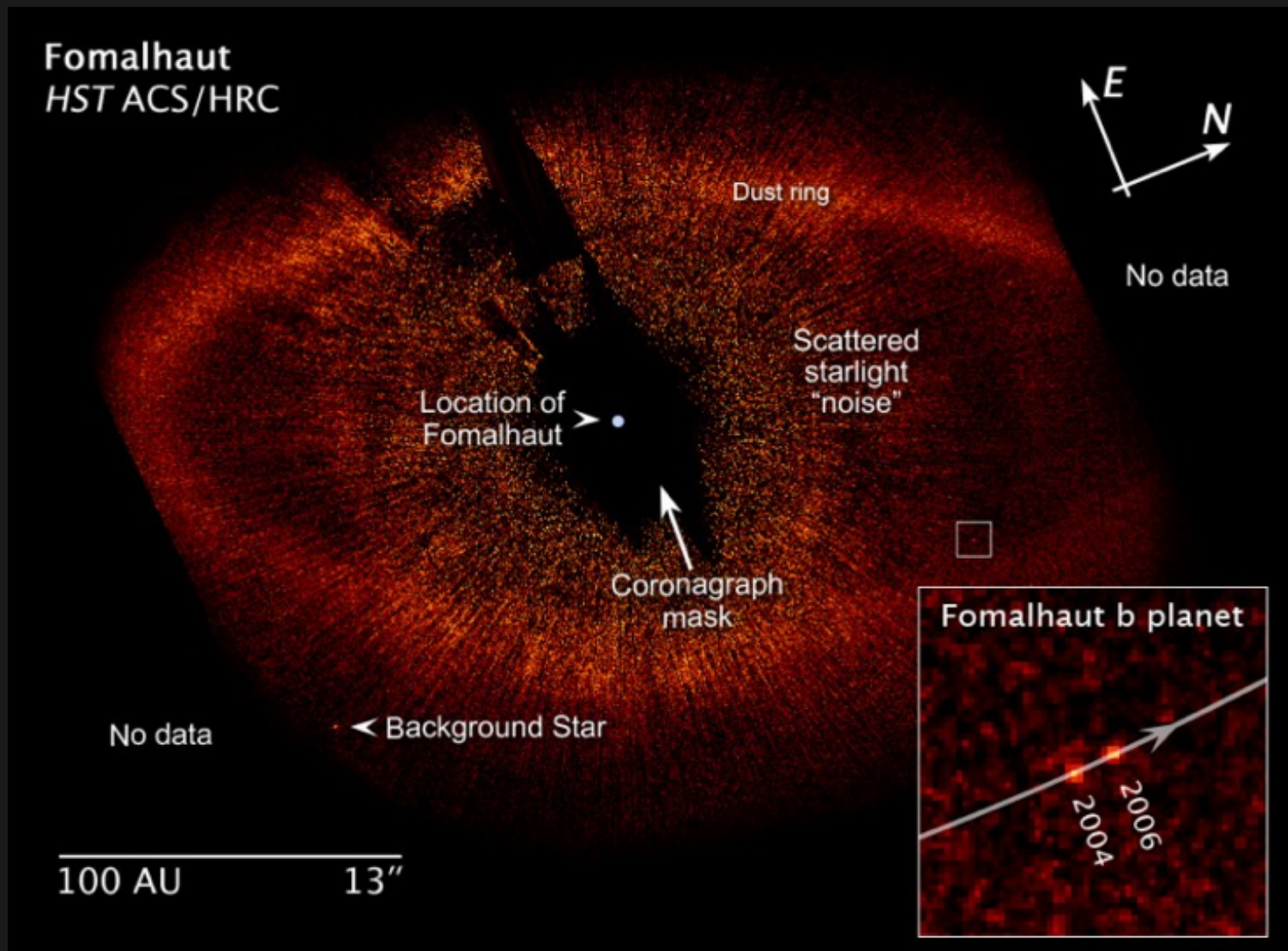

Why Earthlike in Habitable Zone is Hard

- *Bright Star/Faint Planet:* In visible light, our Sun is 10^{10} times brighter than Earth. That's 25 mags.
- *Close to Each Other:* A planet at 1 AU from a star at 10 parsecs can appear at most 0.1 arcseconds in separation.
- *Far from Us:* There are less than 100 Sun-like stars within 10 parsecs.

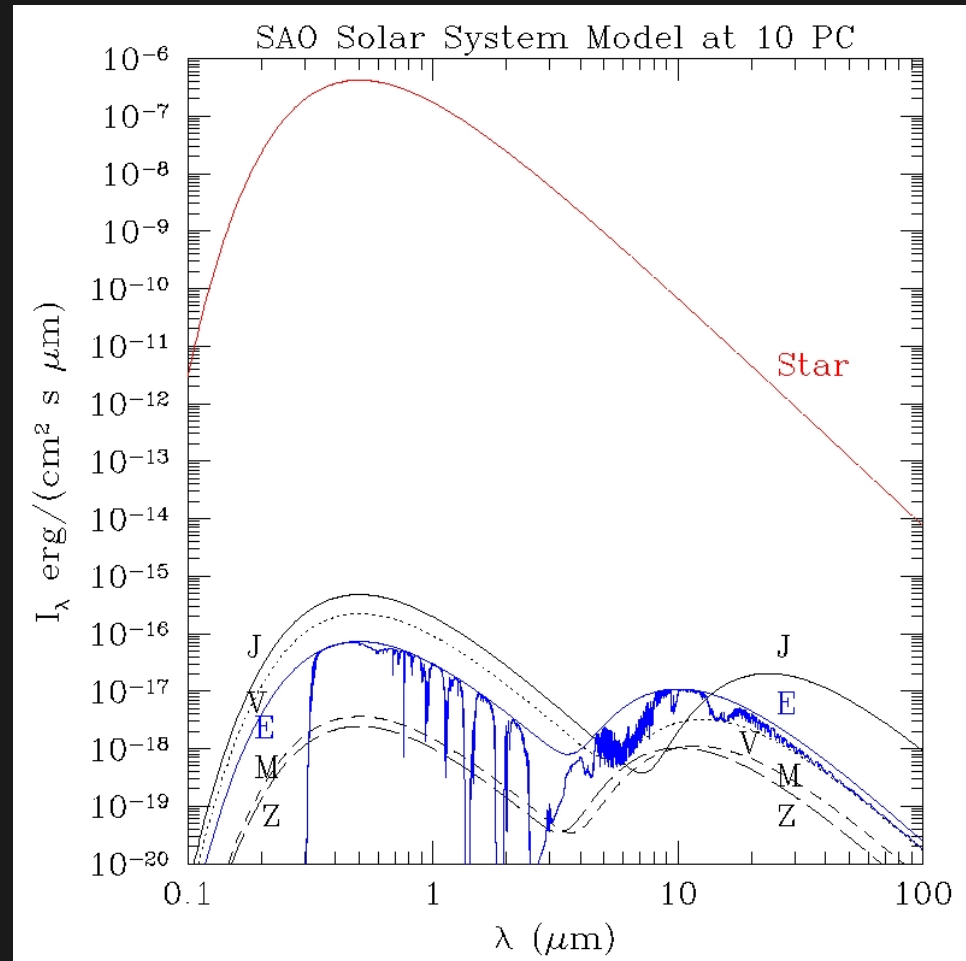

Can Ground-Based Telescopes Do It?



- Atmospheric distortion limits *resolution* to about 1 arcsec.
Note: Resolution refers to equally bright objects.
If one is much brighter than the other, then it is more difficult.
- Segmented optics limits contrast
- Current adaptive optics not good enough

No they can't (at least not yet)!

Can Hubble Do It?

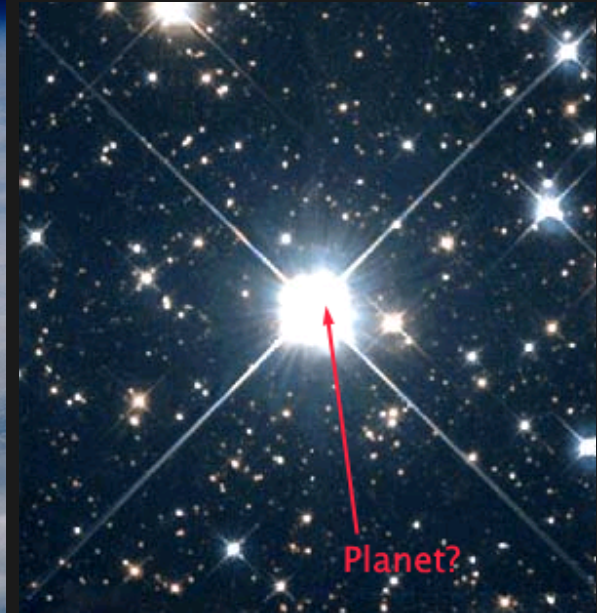

No it can't!

The problem is diffraction

Would have to be $1000\times$ bigger (in each dimension!)

Telescope



Snout

6× Bigger Telescope



Star
Planet

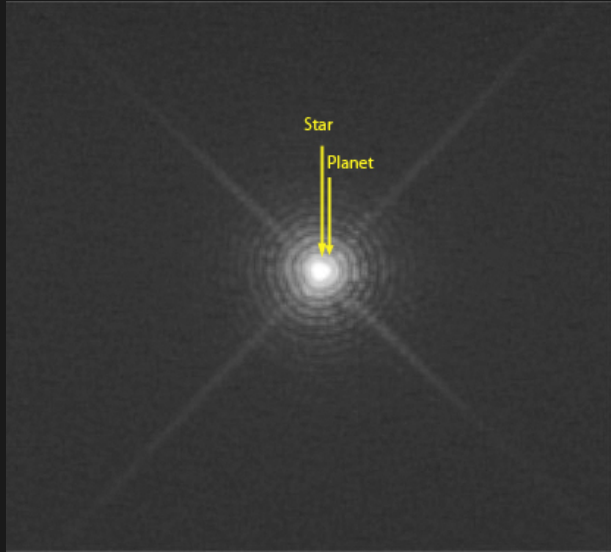

Star
Planet

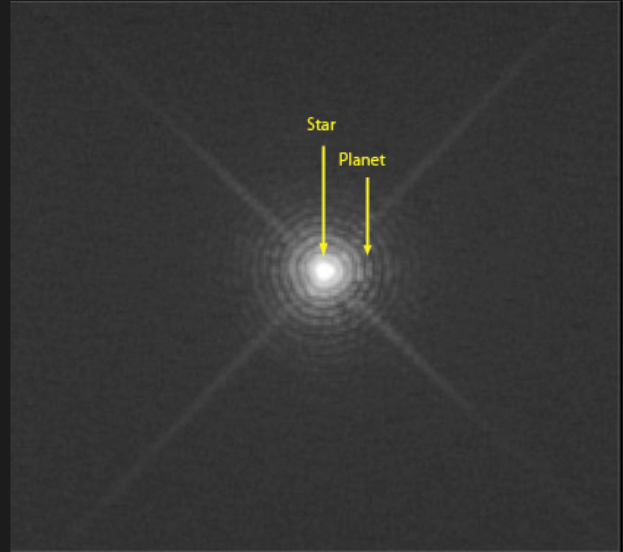

Telescope w/ Unobstructed Aperture

Doesn't Work! Requires an aperture measured in kilometers to mitigate diffraction effects.

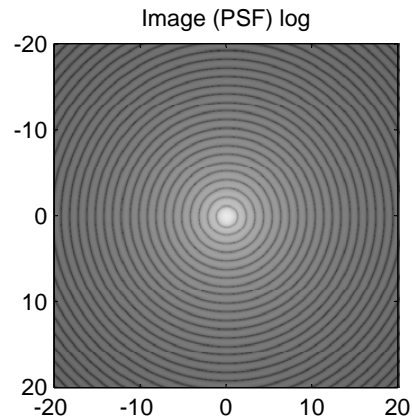
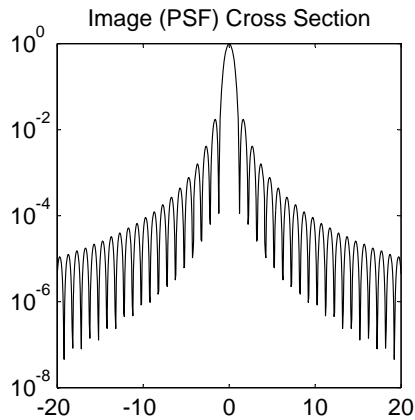
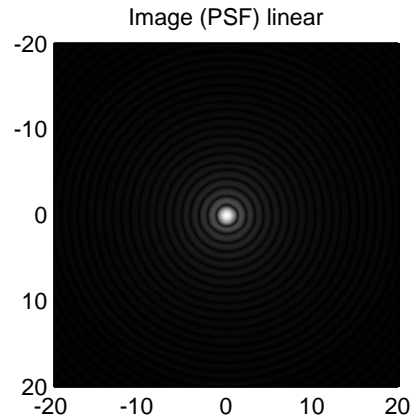
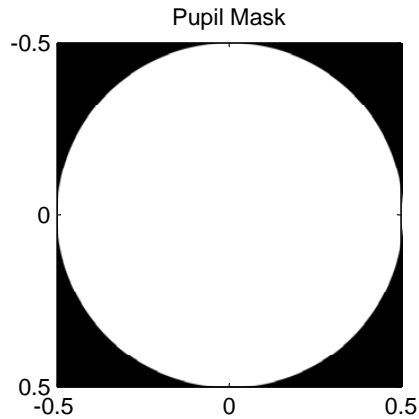

Three Classes of Solutions

- *Nulling Interferometers*
- Internal Coronagraphs
- External Occulters

Space-Based IR Interferometer (TPF-I)

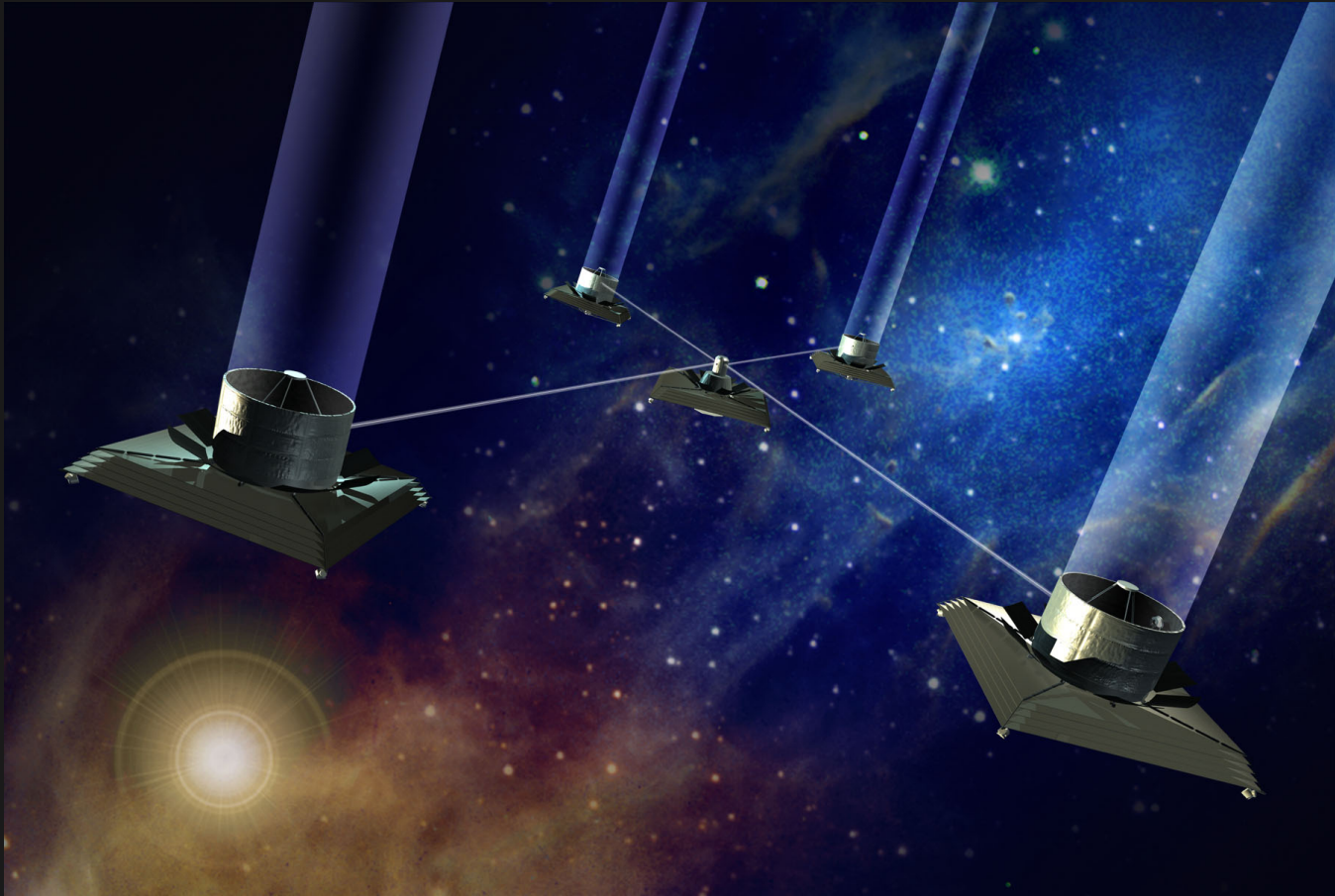

Assessment: It's hard—let the Europeans build it.

Three Classes of Solutions

- Nulling Interferometers
- *Internal Coronagraphs*
- External Occulters

Types of Coronagraphs (TPF-C)

- Classical Lyot Coronagraph
- *Apodized Pupils*
- *Shaped Pupils*
- *Pupil Mapping*
- Optical Vortex
- Phase Masks
- Visible Nuller
- Hybrids

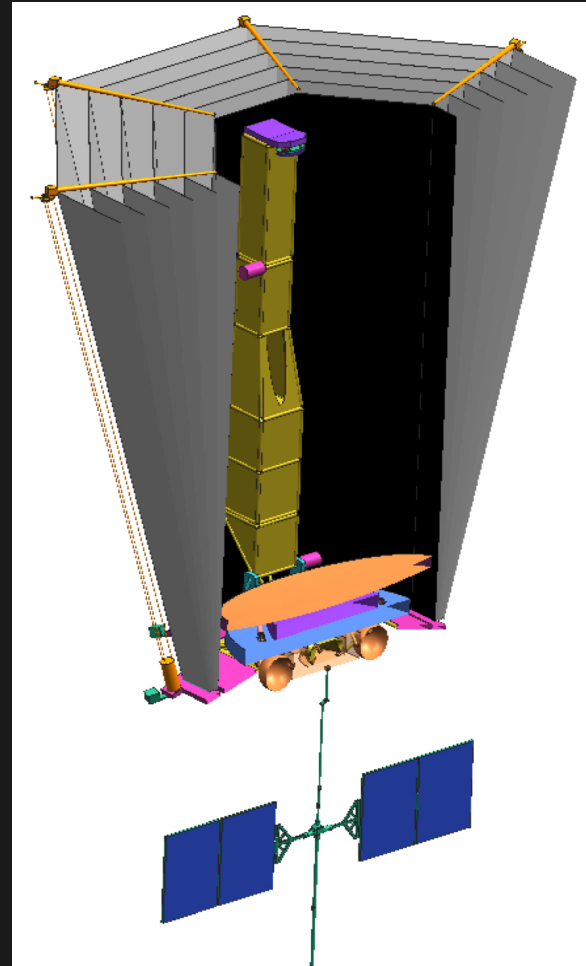

Apodized Pupil Coronagraph

Diffraction Control via Tinting the Pupil

The abrupt edge of the telescope's "mirror" causes the bright diffraction rings.

Solution: Use tinted glass to ease the transition from transparent to opaque.

Some of the Math

The image-plane *electric field* $E()$ produced by an on-axis plane wave (i.e., starlight) and an apodized (i.e., tinted) aperture defined by an *apodization function* $A()$ is given by the *Fourier transform*:

$$E(\xi, \zeta) = \iint e^{i(x\xi + y\zeta)} A(x, y) dy dx$$

●

⋮

$$E(\rho) = 2\pi \int_0^{1/2} J_0(r\rho) A(r) r dr,$$

where J_0 denotes the 0-th order Bessel function of the first kind.

NOTE: The *electric field* depends *linearly* on the *apodization function*.

The *intensity* is the square of the electric field.

The unitless pupil-plane “length” r is given as a multiple of the aperture D .

The unitless image-plane “length” ρ is given as a multiple of focal-length times wavelength over aperture ($f\lambda/D$) or, equivalently, as an angular measure on the sky, in which case it is a multiple of just λ/D . (Example: $\lambda = 0.5\mu\text{m}$ and $D = 10\text{m}$ implies $\lambda/D = 10\text{mas}$.)

Optimization

Find *apodization* function $A()$ that solves:

$$\begin{aligned} &\text{maximize} && \int_0^{1/2} A(r) 2\pi r dr \\ &\text{subject to} && -10^{-5} E(0) \leq E(\rho) \leq 10^{-5} E(0), && \rho_{\text{iwa}} \leq \rho \leq \rho_{\text{owa}}, \\ &&& 0 \leq A(r) \leq 1, && 0 \leq r \leq 1/2, \\ &&& -50 \leq A''(r) \leq 50, && 0 \leq r \leq 1/2 \end{aligned}$$

An infinite dimensional *linear programming* problem.

Pupil with "Optimal" Tinting

Mirror with Softened Edge

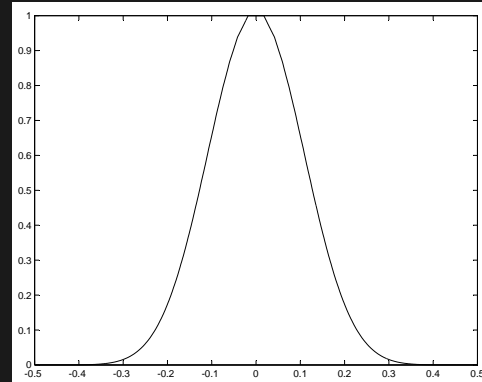
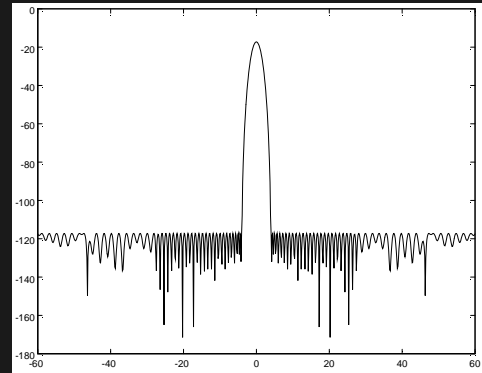
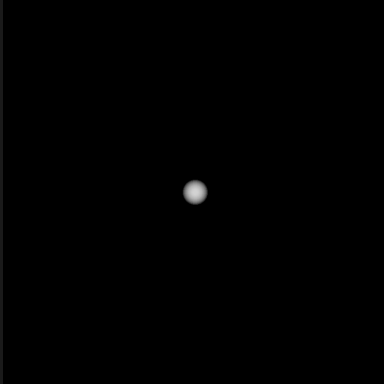

Image of Star



Mathematically Perfect...

But Unmanufacturable!

Shaped Pupil Coronagraph

20 Petal mask

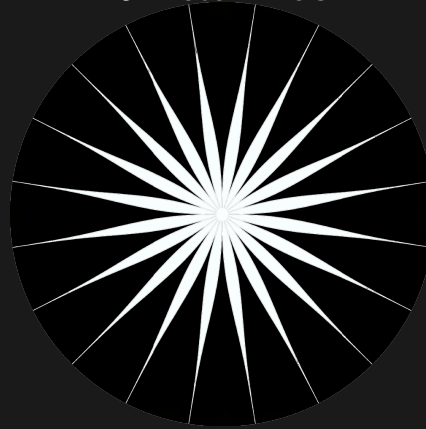

Image plane (20 petals)

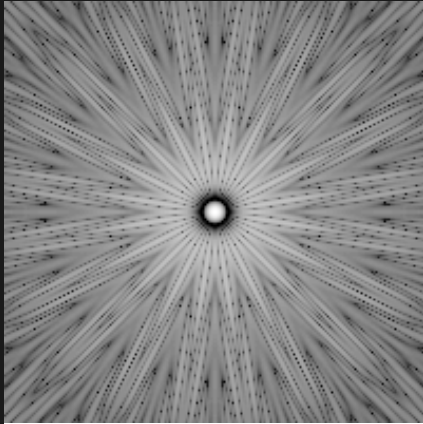
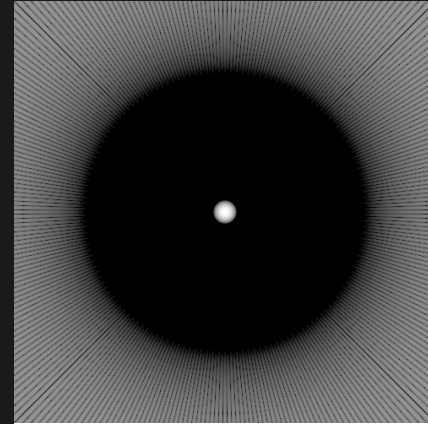

Image plane (150 petals)



Still excellent, but still unmanufacturable.

Ripple3 Mask

Designed for an elliptical 4×8 meter primary.

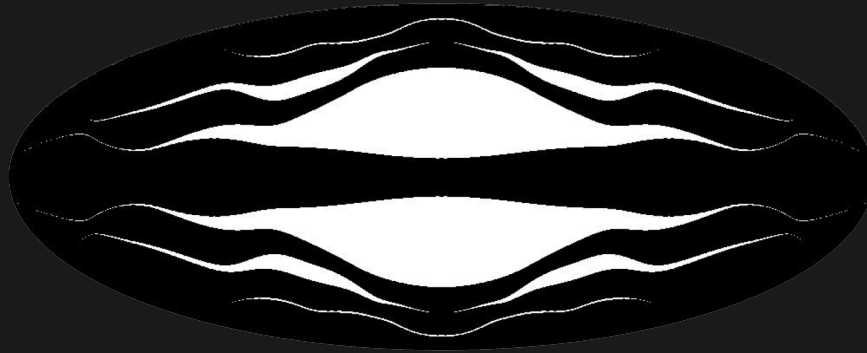

$$\rho_{iwa} = 4$$

Throughput = 30%

Note: throughput measured relative to ellipse

11% central obstr.

Easy to make

Only a few rotations

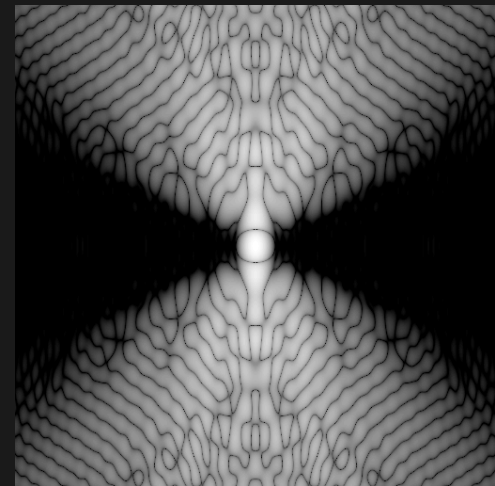

Pupil Mapping (PIAA)

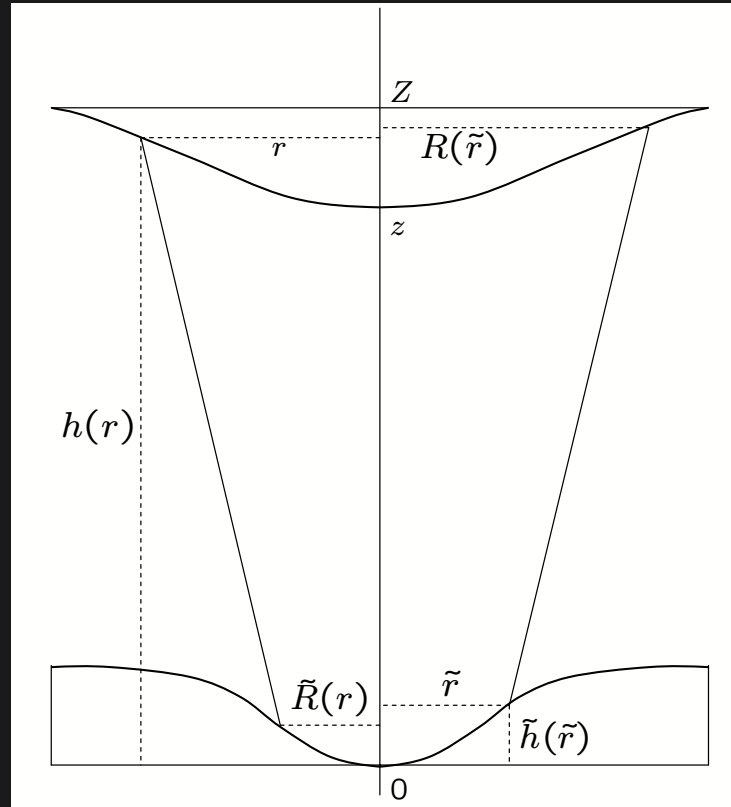
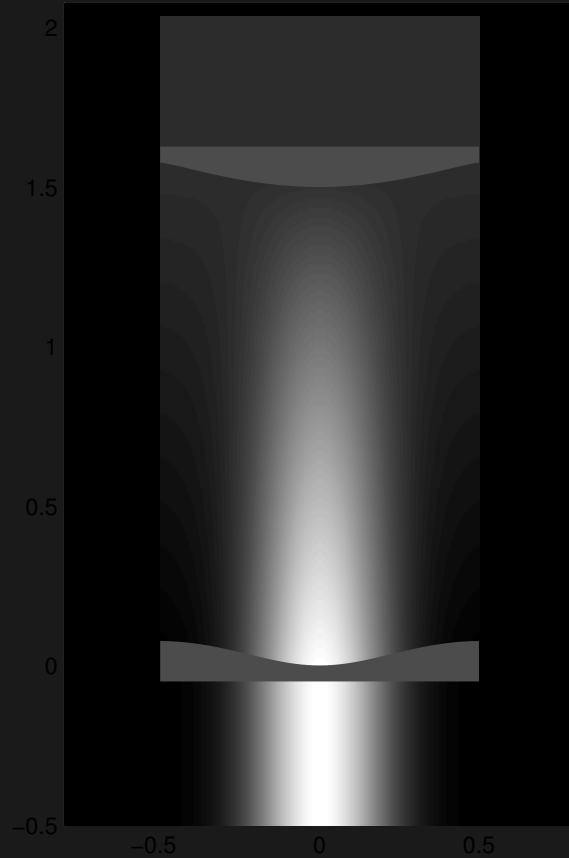

All above methods require optics of extraordinary quality: 1/10,000 wave precision.

Pure PIAA Doesn't Work (Diffraction Analysis)

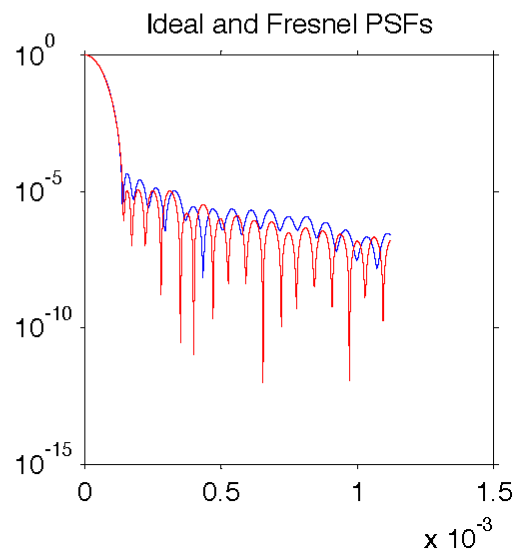
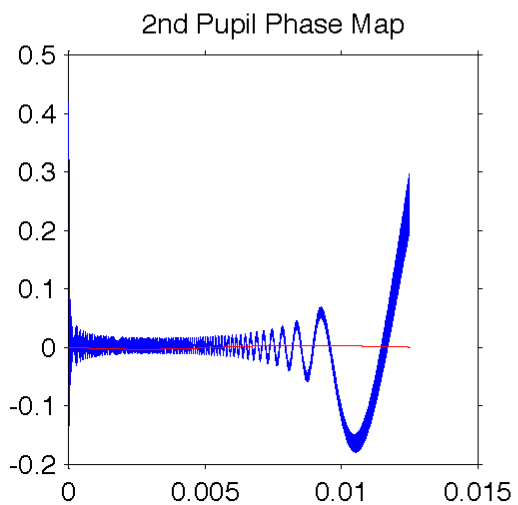
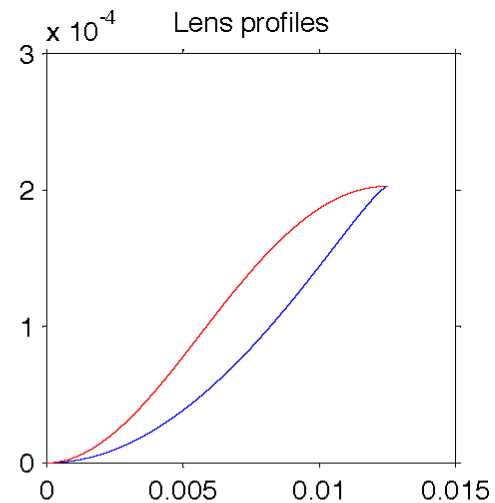
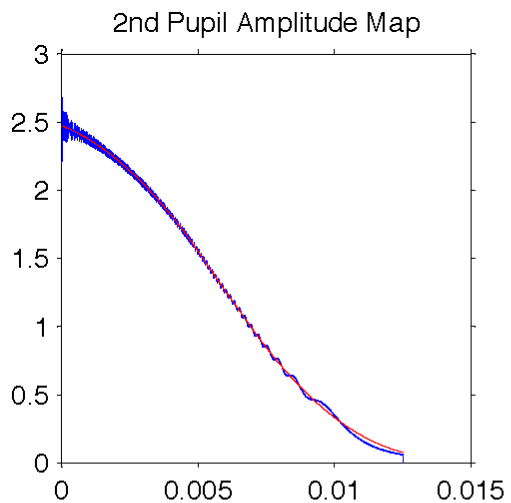

Hybrid PIAA/Apodized-Pupil

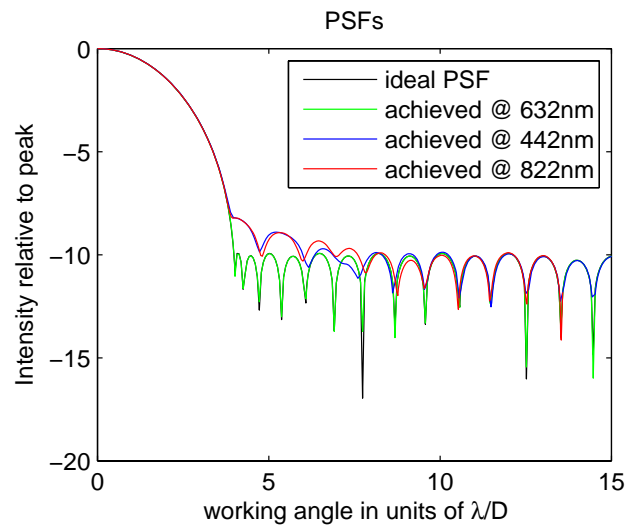
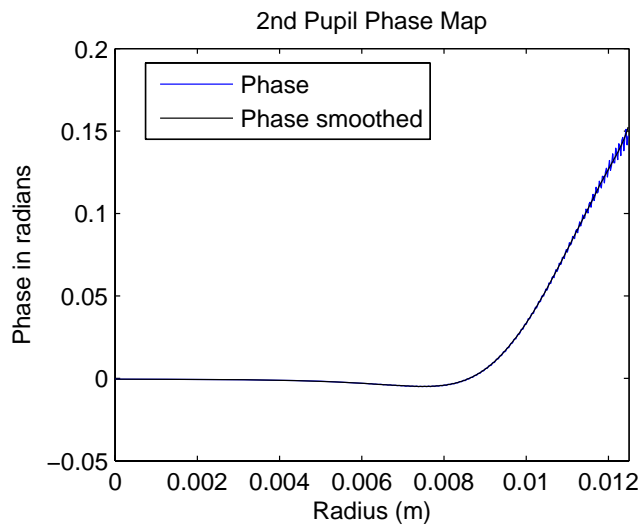
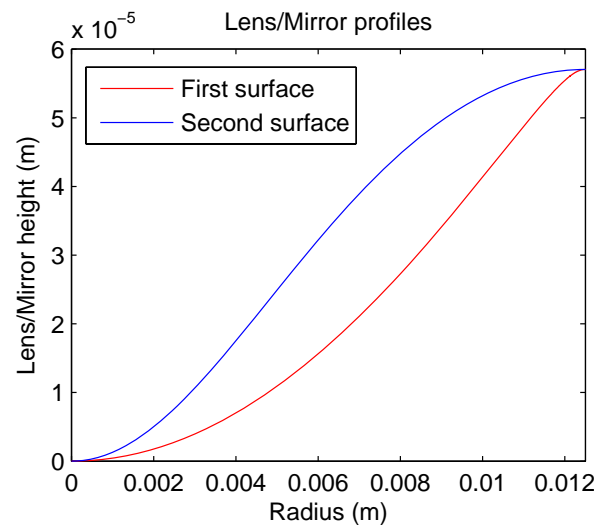
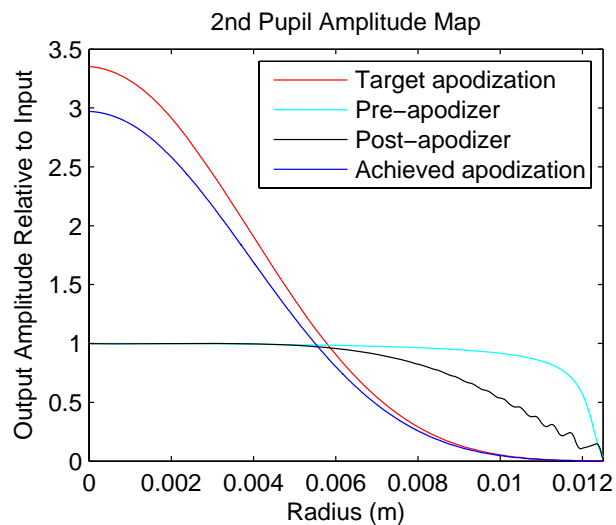

Hybrid-PIAA vs. Shaped-Pupil

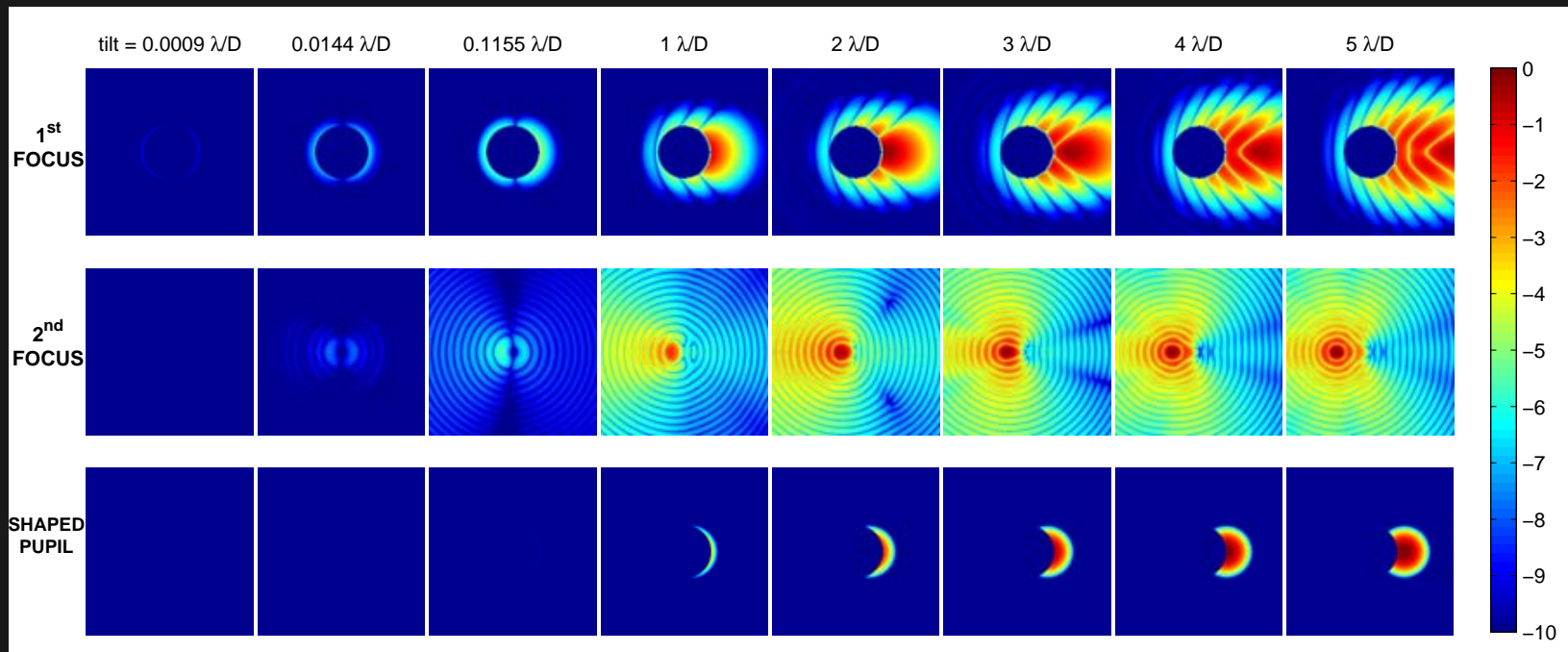

What About Imperfect Optics?

So far, we have assumed perfect optics.

Manufacturing errors are inevitable. They could be partially corrected using deformable mirrors (DMs) and a wavefront sensing system.

Thermal changes, vibrations, and possibly other effects will necessitate a dynamic wavefront control system.

Can we correct wavefront errors enough to achieve 25 magnitudes of contrast?

Neptune

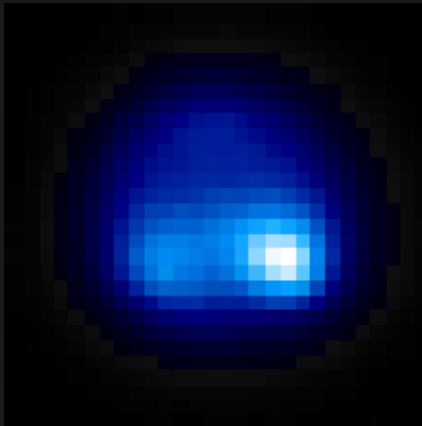

Neptune w/ Adaptive Optics

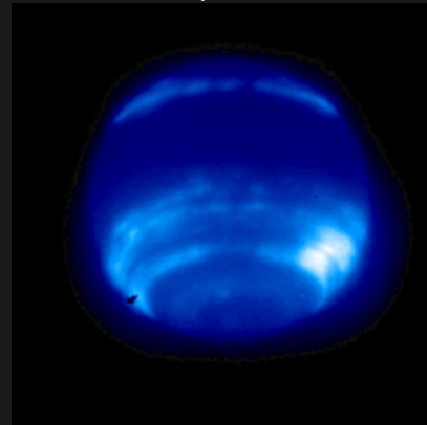

Poke a Single DM-Actuator

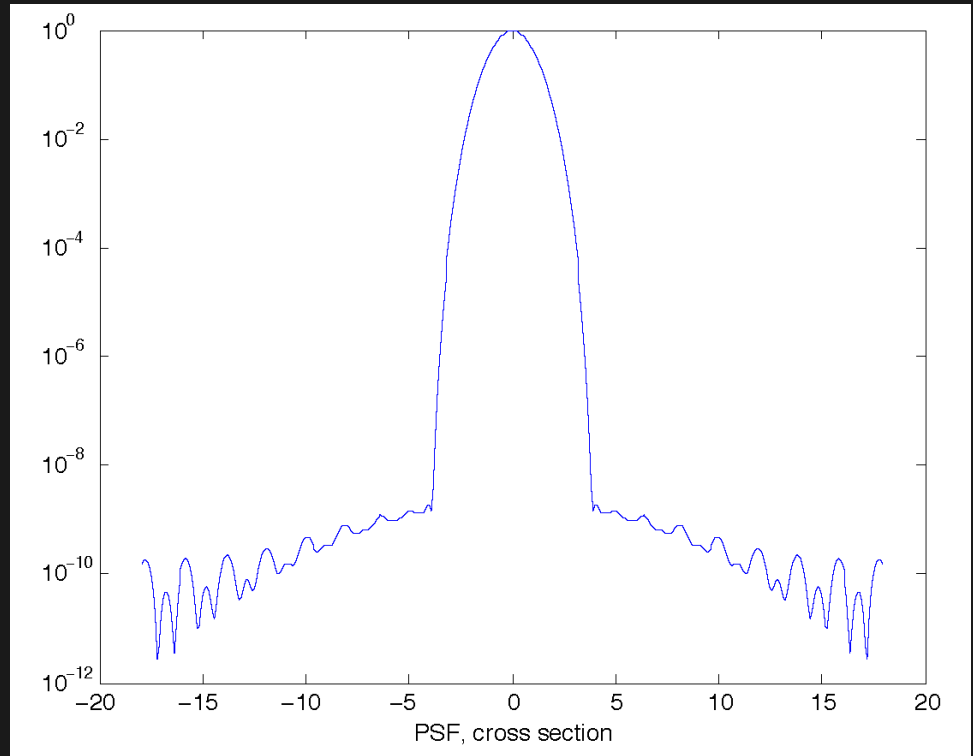
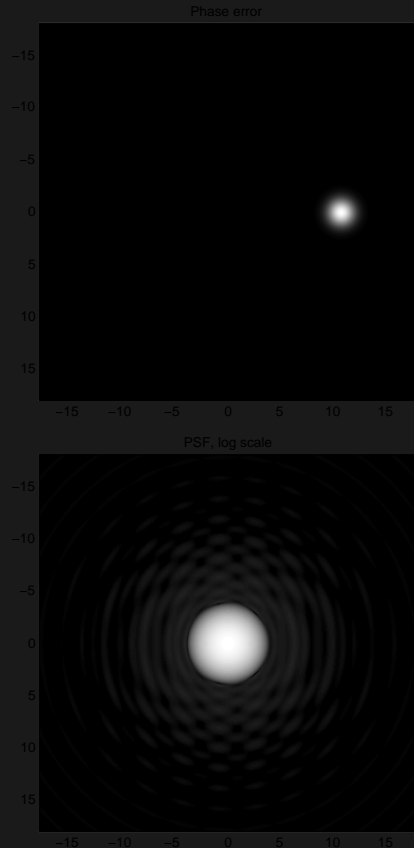

- Left Top:* The phase perturbation associated with giving a single DM-actuator a 10\AA poke.
- Left Bottom:* and the associated PSF plotted on a logarithmic scale.
- Right:* A random cross-sectional plot of the PSF.

Randomly Perturb Actuators

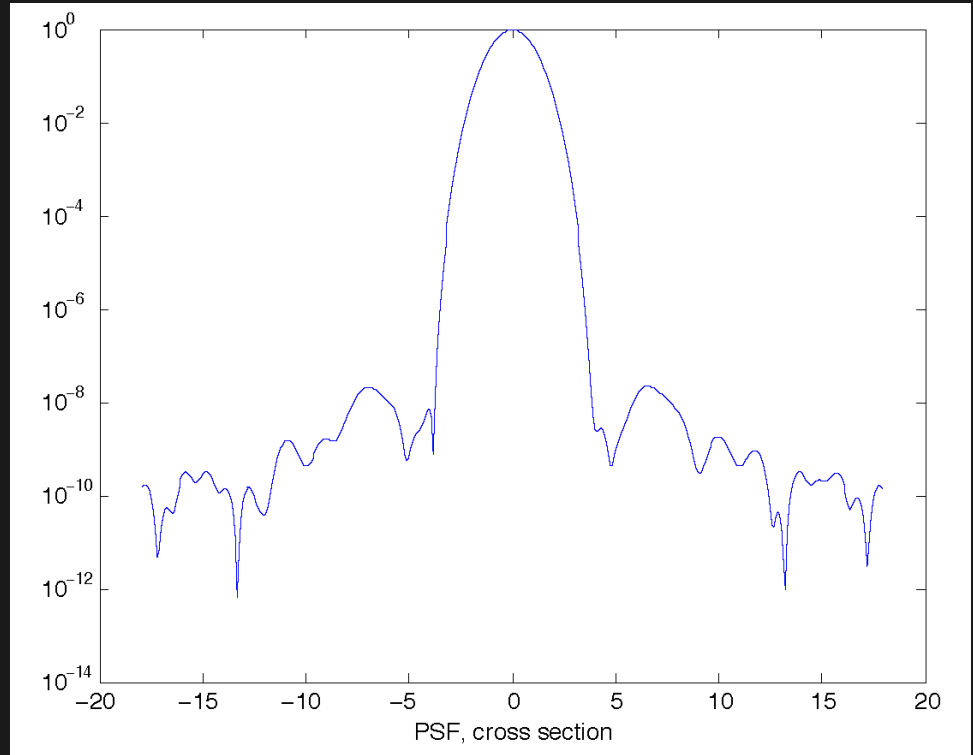
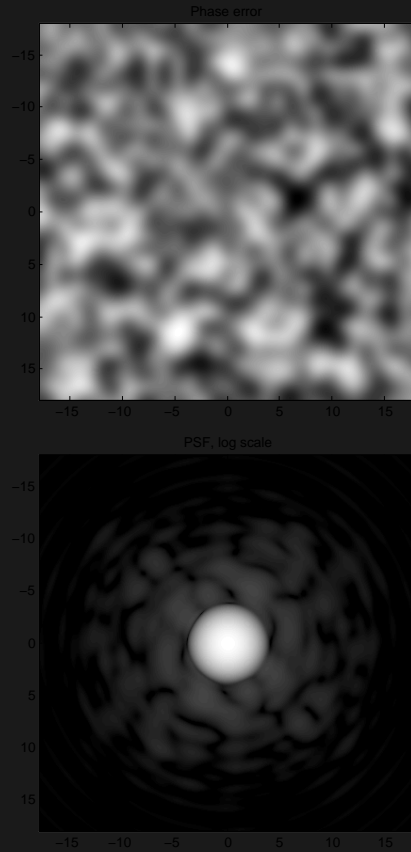

Left Top: The phase perturbation associated with poking each DM-actuator randomly, independently. Each poke is chosen from a uniform distribution between -1 and $+1\text{\AA}$. Due to overlapping influence functions, the largest net upward phase shift is 2.46\AA and the largest downward shift is -2.30\AA .

Our TPF Optics Lab



Jeremy Kasdin tinkers with the laser.

More postcards from the edge...

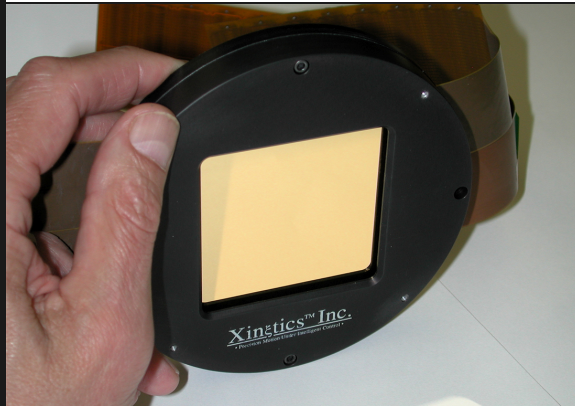
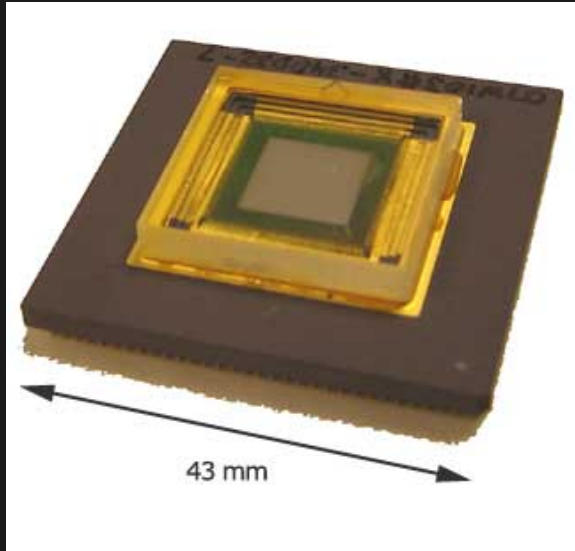

Three Classes of Solutions

- Nulling Interferometers
- Internal Coronagraphs
- *External Occulters*

Nature's Coronagraph

Use an external
occulter to
block the light.



Occulter—Simple Ray Optics Description

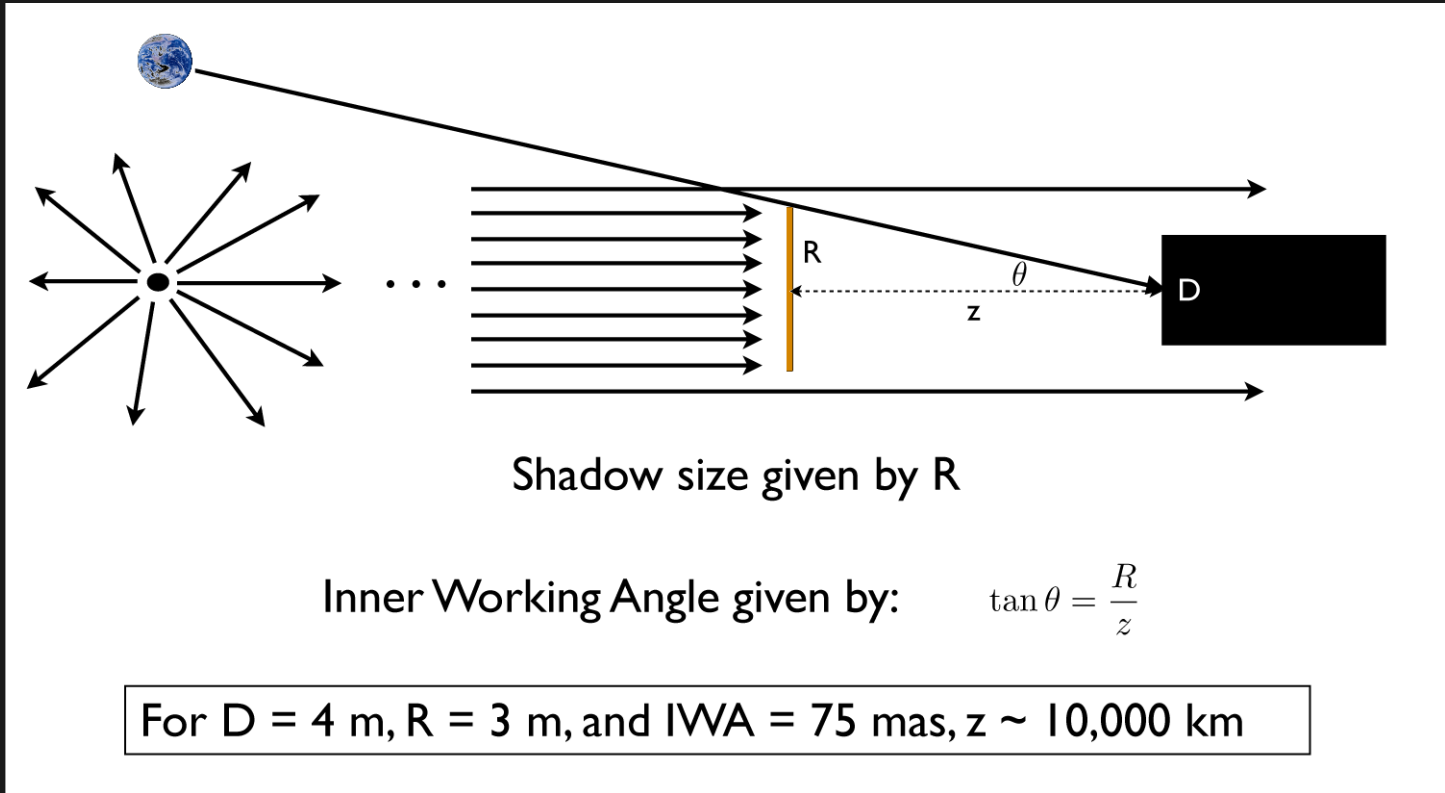

The fundamental size and separation for a starshade are LARGE.

Siméon Poisson/Francois Arago (1818)

Poisson didn't believe the wave theory of light.
He pointed out that light falling on a circular object
would have a bright spot at the center of its shadow.

Arago did the experiment.

Poisson was wrong.

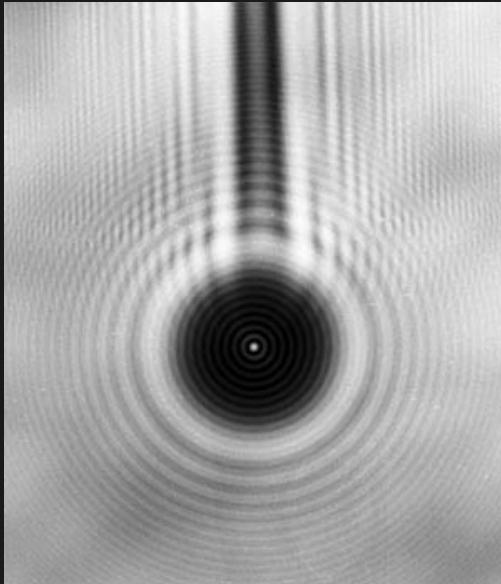

Poisson's spot

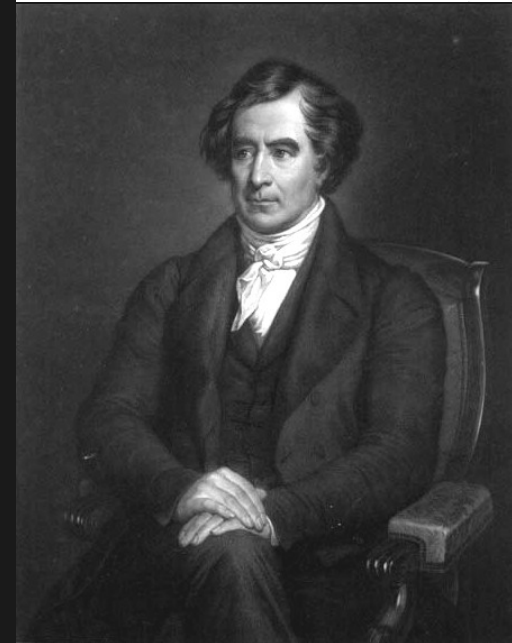

Plain External Occulter (Doesn't Work!)

Circular Occulter

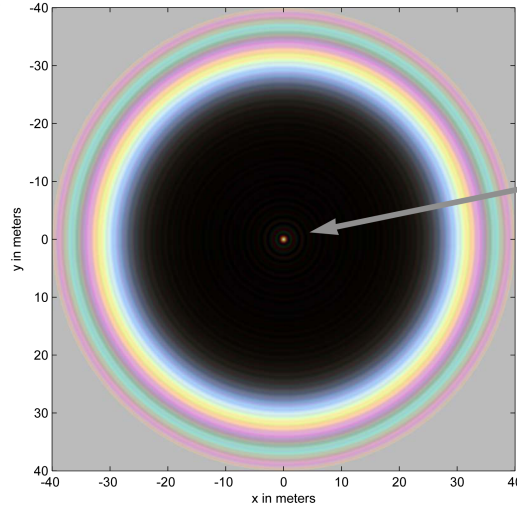
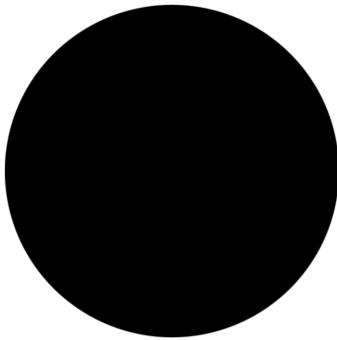

Poisson's Spot!

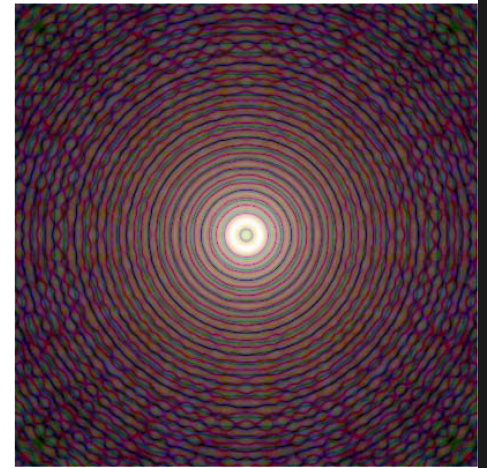

Simulated star/planet image

Shadow isn't dark enough

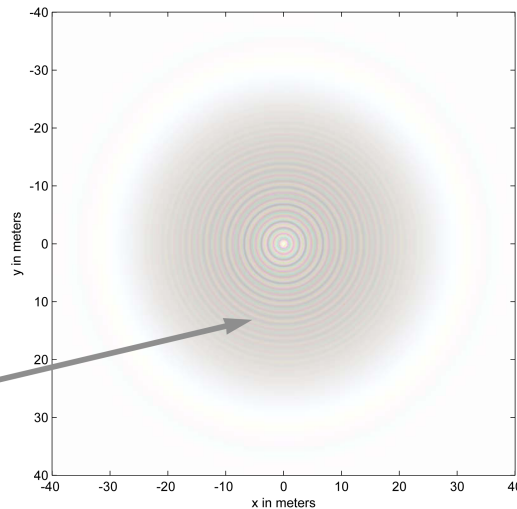

Shaped Occulter

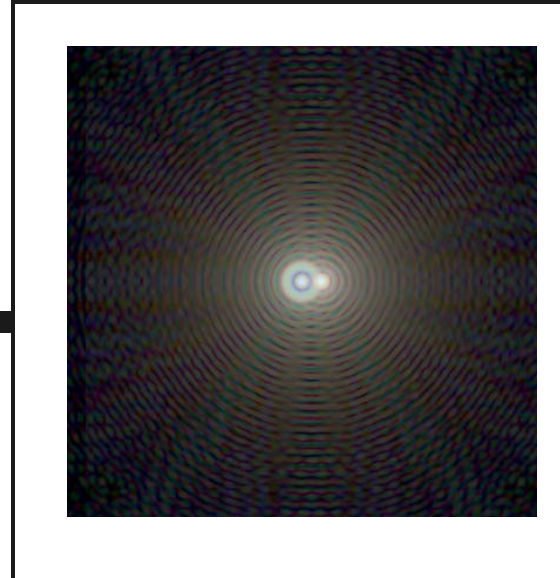
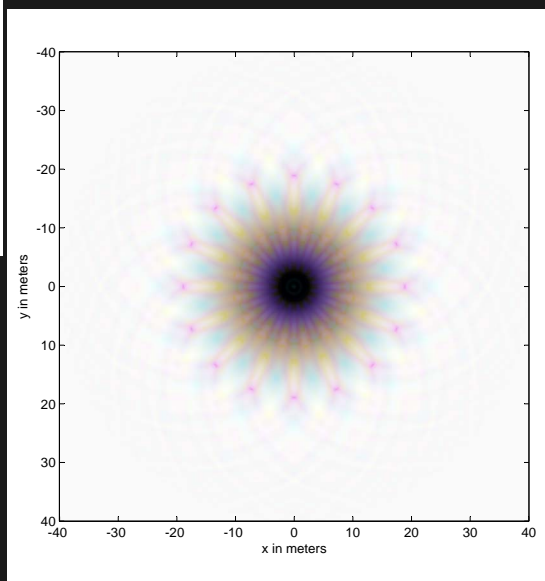
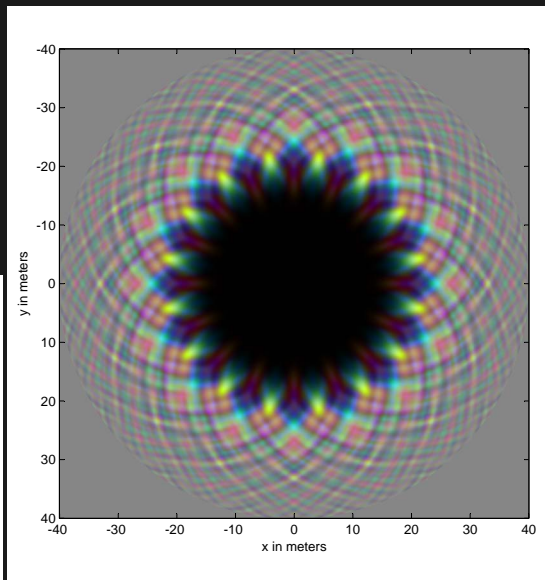
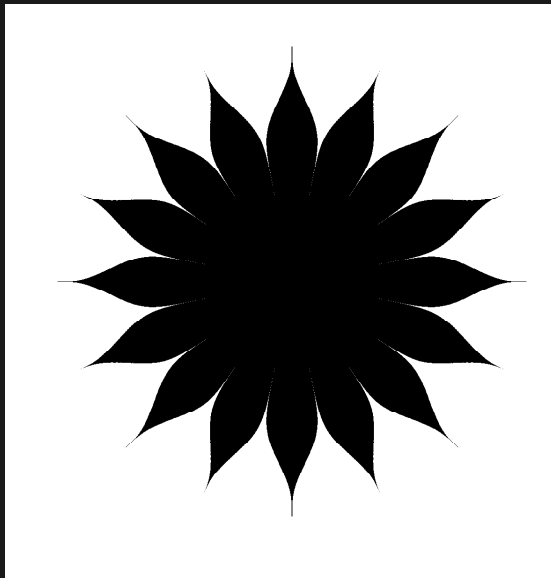

Space-based Occulter (TPF-O)



Telescope Aperture: 4m, Occulter Diameter: 50m, Occulter Distance: 72,000km

Starshade Stowage and Deployment

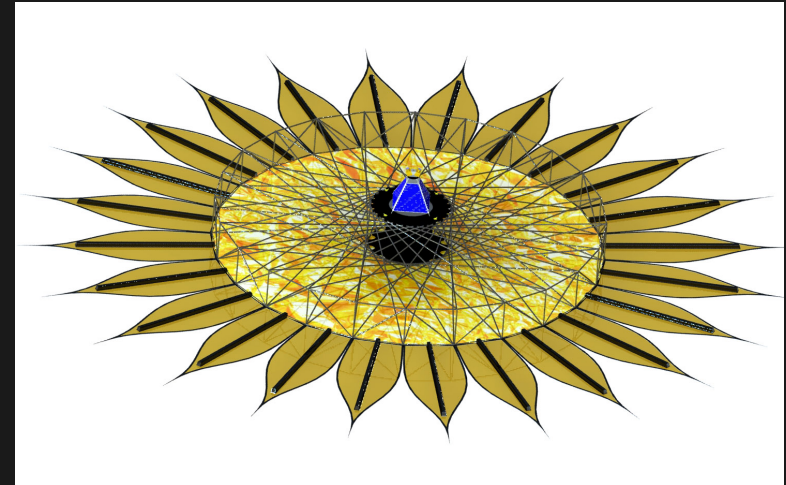
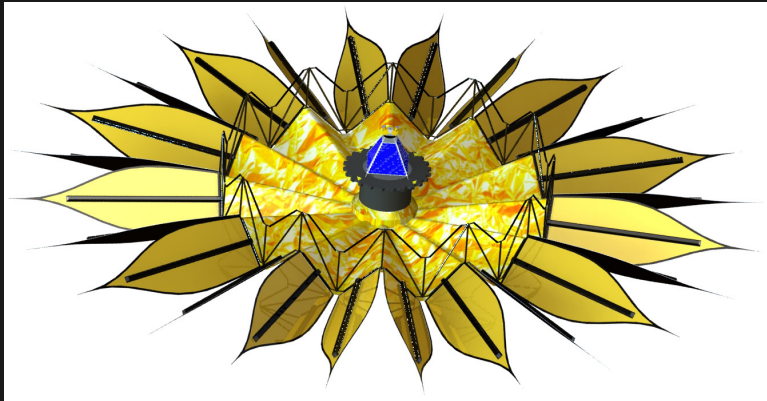
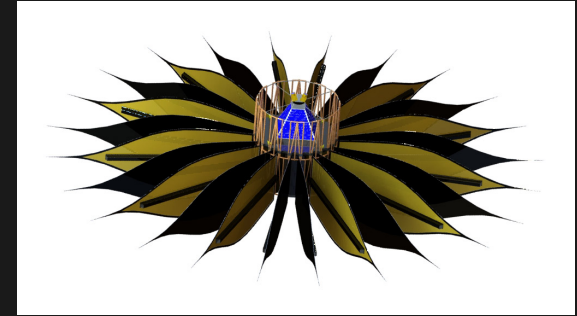
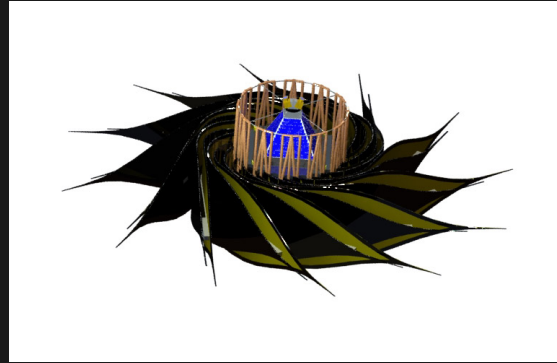

A Real Petal...

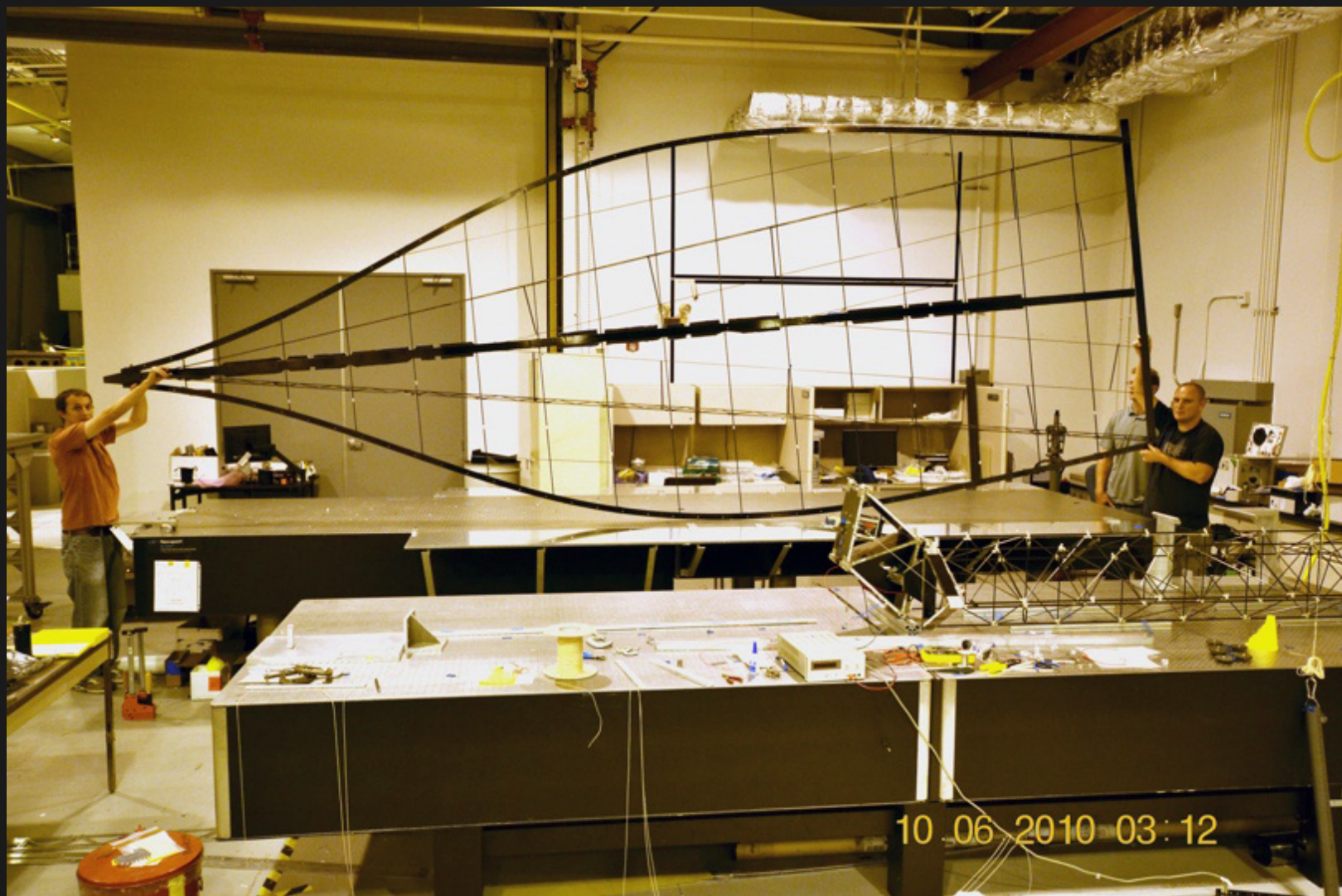

...And How It Folds



Our Solar System From Fomalhaut



Our Solar System From Fomalhaut

2014 01 01 00:00:00 UTC

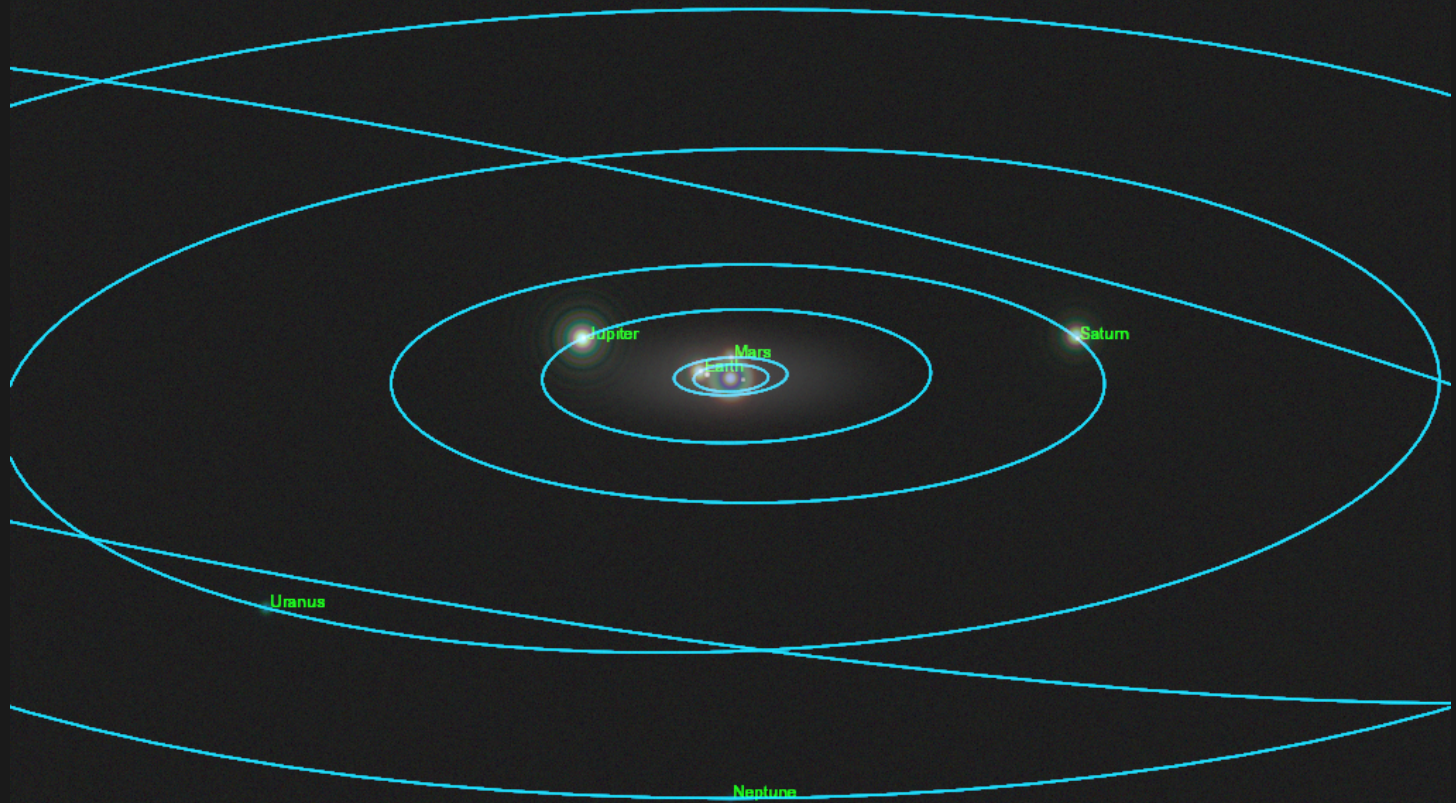

Ground-Based Possibilities

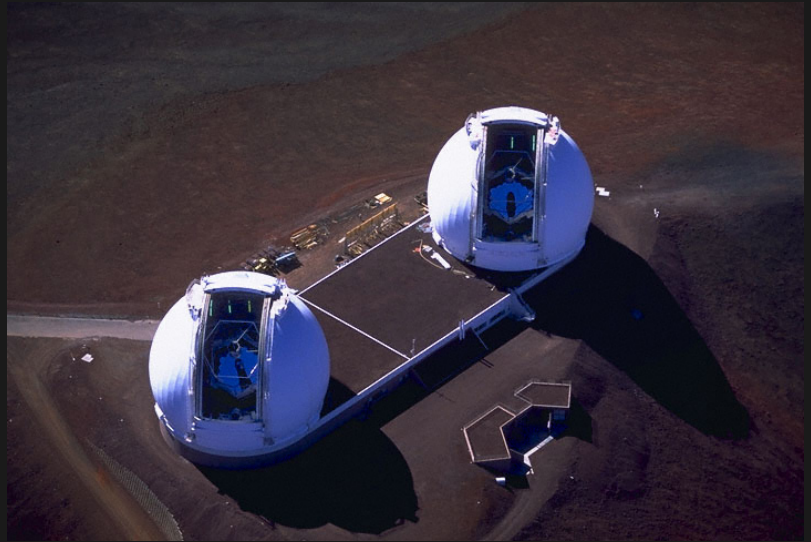

- Atmospheric *seeing* limits resolution to about 1 arcsec.
- Large aperture with adaptive optics.
- Interferometry.

Which Space-Based Observatory Seems Easiest To Build...

Interferometer. A cluster of two to four multi-meter sized infrared telescopes flying in formation at separations on the order of 100 meters with subwavelength precision so that the central star can be attenuated by 25 magnitudes by destructive interference.

Coronagraph. A four to eight meter off-axis telescope with built-in diffraction control scheme and active adaptive optics to maintain unprecedented wavefront quality (1/10,000-th wave) over the course of very long exposures (light throughput of the diffraction control system is only about 10%).

Occluder. A four meter diffraction limited telescope and a specially configured 50 meter tip-to-tip occulter “flying” 72,000 km in front of the telescope with station-keeping to within a ± 1 meter tolerance over the course of a multihour exposure.

REMINDER: We landed humans on the moon and brought them safely home again.